

| | |
|------------------|----------|
| MODEL | SF-50N |
| Process Capacity | 50 L/min |

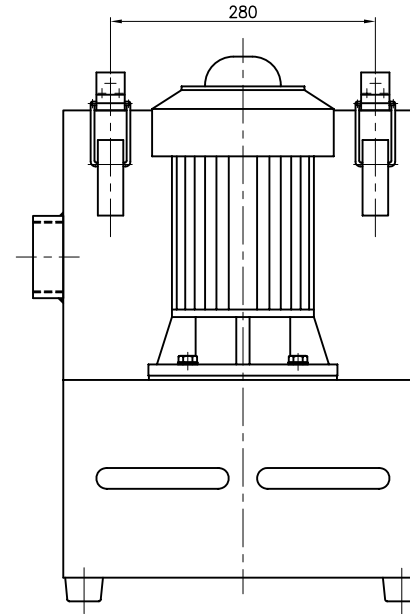

| Q'TY | NO. | PART NO. | NAME | MAT'L | SIZE | WT.(kg) | REMARKS |
|------|-----|----------|---------------|-----------------|--------------------|-----------------------|---------|
| ▲ | | | NOTE | S T A N D A R D | | | |
| ▲ | | | APPD | | TITLE | CENTRIFUGAL SEPARATOR | |
| ▲ | | | CHKD | | SLUDGE FREE SF-50N | | |
| ▲ | | | DESD | | ASS'Y(외형도 -면선장치부착) | | |
| ▲ | | | DRAW/06.07.28 | B.S.LEE | DWG. NO. | SF05N000 | REG. |
| ▲ | | | | | AUX. NO. | | |
| ▲ | | | | | | | |
| ▲ | | | | | | | |
| ▲ | | | | | | | |
| ▲ | | | | | | | |
| ▲ | | | | | | | |
| ▲ | | | | | | | |
| ▲ | | | | | | | |
| ▲ | | | | | | | |
| ▲ | | | | | | | |
| ▲ | | | | | | | |

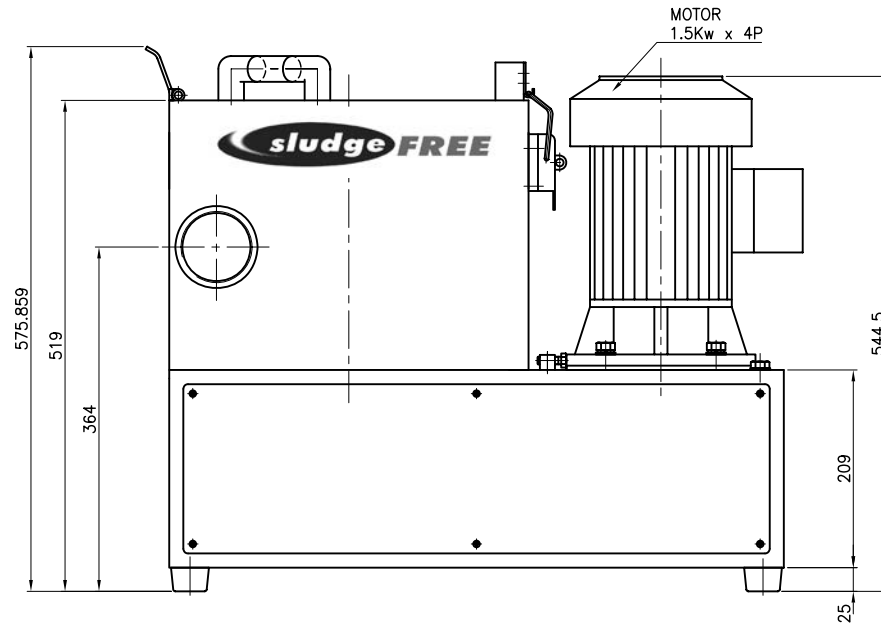